

MASTER BALANCER



licht
ergonomisch
handzaam
snel
veilig
betrouwbaar

BPL 

solutions in **handling**



licht



snel



ergonomisch

BPL 



handzaam

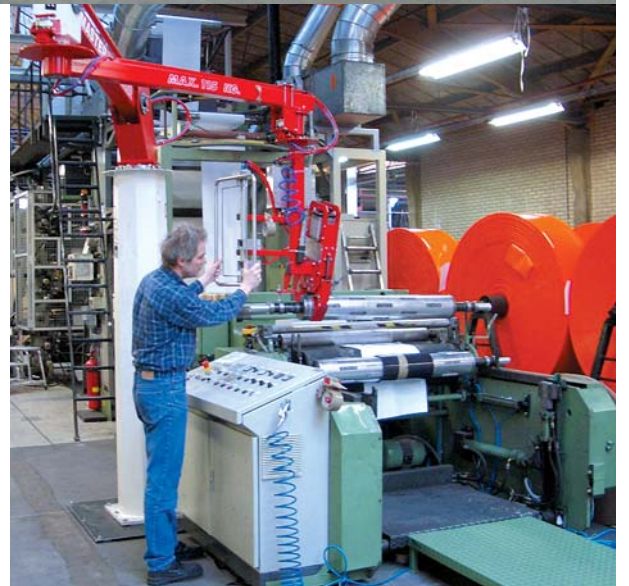

solutions in handling



quick info

- Extreem wendbaar
- Heffingen comfortabel en fijngevoelig
- Omvangrijke opnamemogelijkheden
- Regelbare snelheden
- Groot bereik
- Neemt weinig plaats in beslag
- Strenge hygiëne toepasbaarheid:
 - vacuümbuffer
- Beveiligingen:
 - gewicht detectie
 - productaanwezigheid controle
 - vacu controle indien van toepassing
 - tegen overbelasting
- Volledig pneumatisch
- Ex. proof
- Stil of geluidsarm
- Design in vorm, kleur en techniek

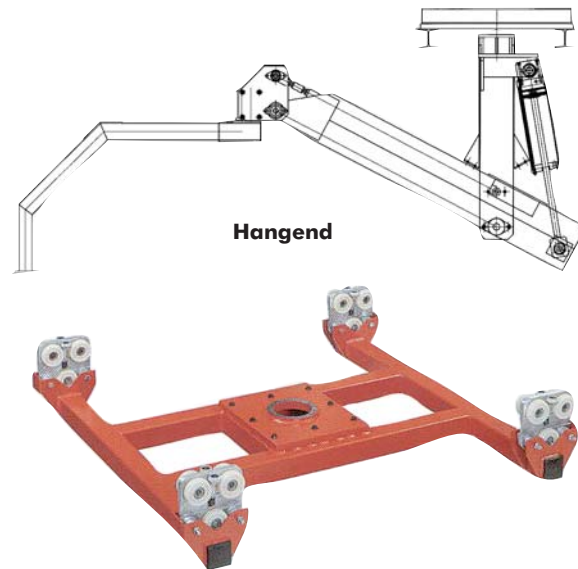
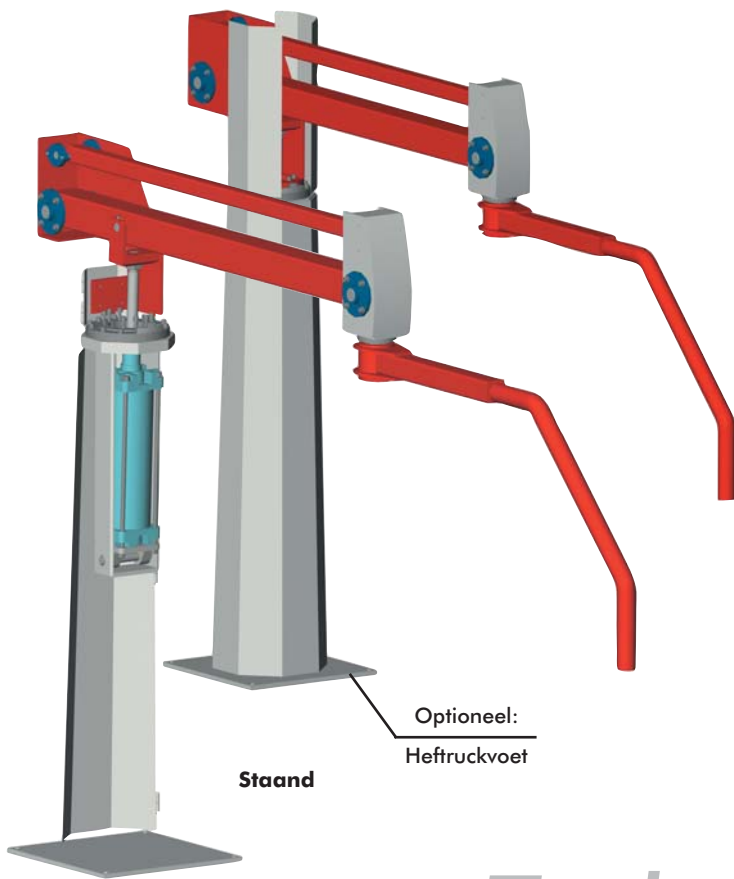

Technische gegevens



| | |
|--|--|
| Type besturing: | - Self-Balancer - Regelbare snelheid |
| Hefcapaciteiten: (incl. product opname) | 20 900 (kg) |
| Slag: | max. 1750 (mm) |
| Reikwijdte: | Rmax. 4000 (mm) |
| Uitvoering: | Staand (op kolom) Hangend (vaste positie) Hangend (en verrijdbaar) |
| Afwerking: | Staal gecoat |
| Opties: | RVS Verplaatsbaar |



veilig



betrouwbaar

Dit is een kleine impressie van oplossingen in verschillende ergonomische handling. De bedoeling is dat we met weinig tekst en vooral veel voorbeelden alles willen zeggen. Ergonomisch handlen betreft namelijk veel toepassingen; van rollen, dozen en platen tot toiletputten of kazen.

Er is geen mogelijkheid iedere toepassing te laten zien, want bijna iedere handlingsituatie is speciaal. Wil iemand echter de ideale oplossing zien? Wij tonen hem wel degelijk graag, vanuit de basis, de **Master Balancer**. Deze basis, de **BPL-Master Balancer**, heeft per definitie alle voordelen die iedere werkplek nodig heeft! Om er een paar te noemen: extreem wendbaar, licht, ergonomisch, handzaam, veilig en neemt bovendien weinig plaats in beslag!





Doc: 06-04-2005
Designed by Handling, Ontwerp & D.T. P. van der Vliet

BPL Nederland
 De Giesel 19A, 6081 PG Haelen
 Postbus 4120, 6080 AC Haelen
 Tel.: NL. (+31) (0)475-590102
 Fax: NL. (+31) (0)475-590108
 E-mail: bpl@brubek.nl
www.BPLhandling.com

BPL Deutschland
 Postfach 1286, D-53349 Rheinbach
 Tel.: (+49) (0) 2226-168692
 E-mail: bpl@handhabungen.com

BPL België / Belgique
 B-9100 Sint Niklaas



solutions in **handling**